

Rocktech Displays Limited



Module P/N: RK040BF252

Version: 1.0

Description : 4.0 inch TFT 720*720 Pixels with
LED backlight, Round shape, All
viewing angle, 400 nits brightness

TEL: 0086-755-26065260

Fax: 0086-755-26065261

E-mail: Sales@rocktech.com.hk

Web: www.rocktech.com.hk

Revision History

Date	Rev.	Page	Description
2024-06-15	1.0	All	First issue

CONTENTS

- GENERAL FEATURES
- ABSOLUTE MAXIMUM RATINGS
- ELECTRICAL SPECIFICATIONS
- OPTICAL SPECIFICATIONS
- BLOCK DIAGRAM
- PIN DESCRIPTION
- TIMING CHARACTERISTICS
- OUTLINE DIMENSION
- RELIABILITY AND INSPECTION STANDARD
- PRECAUTIONS

1. General Features

Item	Spec	Remark
Display Mode	Normally Black transmissive	
Viewing Angle	FREE	IPS
Input Signals	MIPI	
Outside Dimensions	105.6(W) x109.87(H) x2.18(D)	
Active Area	101.52mm(W)×101.52mm(H)	
Number of Pixels	720(RGB)×720	
Dot Pitch	0.141mm(W) ×0.141mm(H)	
Pixel Arrangement	RGB Vertical stripes	
Drive IC	ST7703	

2. Absolute Maximum Ratings

The following are maximum values which, if exceeded may cause operation or damage to the unit.

ITEM	Sym.	Min.	Typ.	Max.	Unit	Remark
Power for Circuit Driving	VDD	-0.3	-	5.5	V	
Backlight Forward Current	I _{LED}	-	-	25	mA	For each LED
Storage Temperature	T _{ST}	-30	-	80	°C	
Operating Ambient Humidity	H _{OP}	10	-		%RH	
Operating Ambient temperature	T _{OP}	-20	-	70	°C	

3. Electrical Specification

3.1 Driving TFT LCD Panel

Item		Sym.	Min	Typ.	Max	Unit	Note
Power for Circuit Driving		IOVCC	1.65	1.8	2.0	V	
		VDD (+5V)	4.5	+5	6.0	V	
		VDD (-5V)	-6.0	-5	-4.5	V	
Logic Input Voltage	Low Voltage	V _{IL}	-0.3	-	0.3VDD	V	
	High Voltage	V _{IH}	0.7VDD	-	VDD	V	
Logic Output Voltage	Low Voltage	V _{OL}	0	-	0.2VDD	V	
	High Voltage	V _{OH}	0.8VDD	-	VDD	V	

3.2 Driving Backlight

Item	Sym.	Min	Typ.	Max	Unit	Note
Backlight driving voltage	V _F	-	24	-	V	
Backlight driving current	I _F	30	40	50	mA	
Backlight Power Consumption	W _{BL}	-	960	-	mW	
Life Time	-	-	50,000	-		Note 3

Note 1: (Unless specified, the ambient temperature Ta=25°C)

Note 2: The recommended operating conditions refer to a range in which operation of this product is guaranteed. Should this range is exceeded, the operation cannot be guaranteed even if the values may be without the absolute maximum ratings.

Note 3: If LED is driven by high current, high ambient temperature & humidity condition. The life time of LED will be reduced. Operating life means brightness goes down to 50% initial brightness. Typical operating life time is estimated data.

4. Optical Specifications

Optical characteristics are determined after the unit has been 'ON' and stable for approximately 30 minutes in a dark environment at 25 °C. The values specified are at an approximate distance 500mm from the LCD surface at a viewing angle of Φ and θ equal to 0°.

Item	Sym.	Values			Unit	Note
		Min.	Typ.	Max.		
1) Contrast Ratio	C/R	1000	1200	-		FIG.1
2) Module Luminance	L	350	400	-	cd/m ²	FIG.1
3) Response time	Tr+Tf	-	30	-	ms	FIG.2
4) Viewing Angle	θ_T	80	85	-	Degree	FIG.3
	θ_B	80	85	-		
	θ_L	80	85	-		
	θ_R	80	85	-		
5) Chromaticity	Wx	0.252	0.292	0.332		
	Wy	0.297	0.337	0.377		
	Rx	-	-	-		
	Ry	-	-	-		
	Gx	-	-	-		
	Gy	-	-	-		
	Bx	-	-	-		
	By	-	-	-		

◆ Measurement System

Notes:

1. Contrast Ratio(CR) is defined mathematically as :

$$\text{Contrast Ratio} = \frac{\text{Surface Luminance with all white pixels}}{\text{Surface Luminance with all black pixels}}$$
2. Surface luminance is the center point across the LCD surface 500mm from the surface with all pixels displaying white. For more information see FIG 1.
3. Response time is the time required for the display to transition from white to black (Rising Time, Tr) and from black to white (Falling Time, Tf). For additional information see FIG 2.
4. Viewing angle is the angle at which the contrast ratio is greater than 10. The angles are determined for the horizontal or x axis and the vertical or y axis with respect to the z axis which is normal to the LCD surface. For more information see FIG 3.

FIG. 1 Optical Characteristic Measurement Equipment and Method

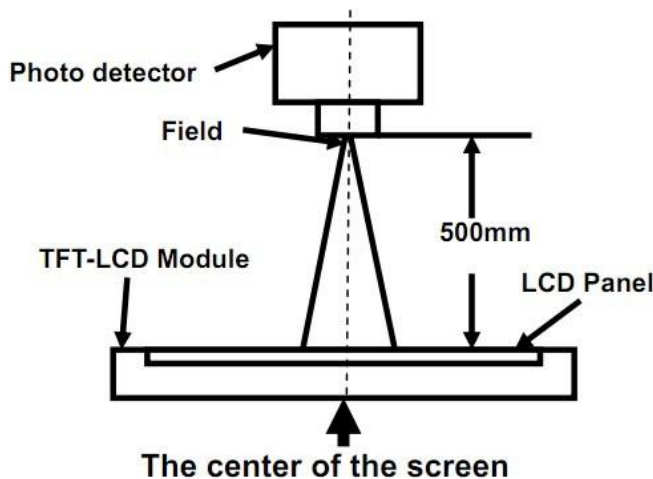

Item	Photo detector	Field
Contrast Ratio	SR-3A	1°
Luminance		
Chromaticity		
Lum Uniformity		
Response Time	BM-7A	2°

FIG. 2 The definition of Response Time

The response time is defined as the following figure and shall be measured by switching the input signal for “black” and “white”.

$$\text{Response Time} = \text{Rising Time}(Tr) + \text{Falling Time}(Tf)$$

- Rising Time(Tr) : Full White 90% \rightarrow Full White 10% Transmittance.
- Falling Time(Tf) : Full White 10% \rightarrow Full White 90% Transmittance.

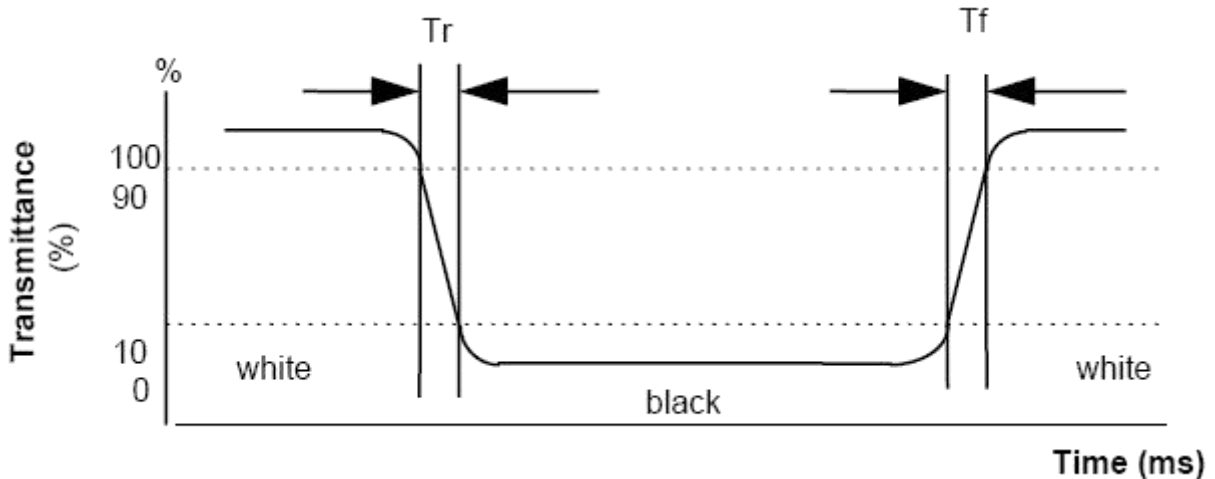
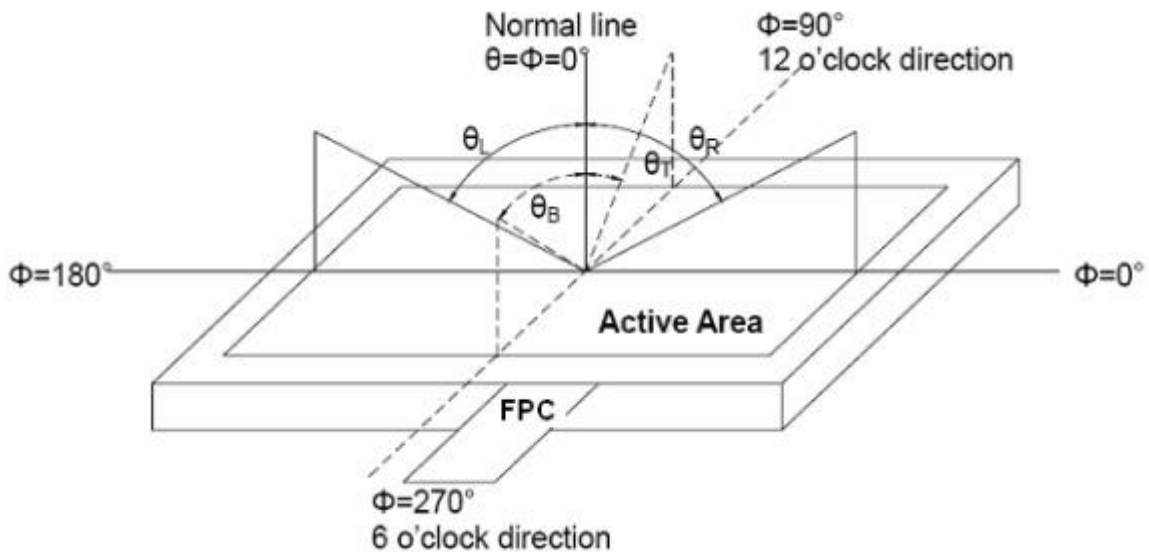
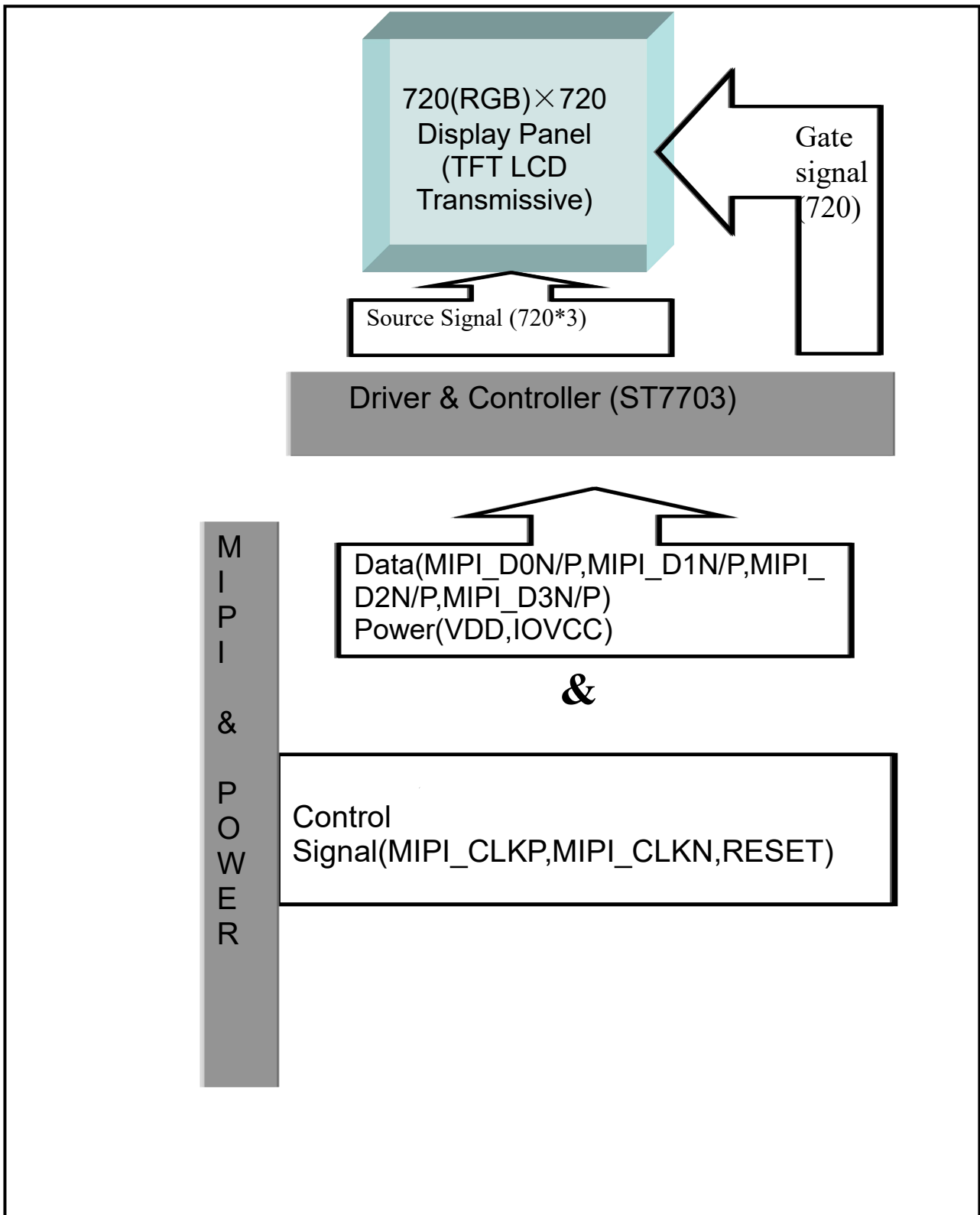

FIG. 3 The definition of Viewing Angle

Use Fig. 1 (Test Procedure) under Measurement System to measure the contrast from the measuring direction specified by the conditions as the following figure.



5. Block Diagram



6.Pin Description

Item	Terminal	Functions
1	GND	Connect 1k resistor to GND
2-3	LEDA	Backlight Power Input Pin anode
4-5	LEDK	Backlight Power Input Pin cathode
6	GND	Ground
7-8	VDD(-5V)	Power supply -5V
9	GND	Ground
10-11	VDD(+5V)	Power supply +5V
12	GND	Ground
13-14	IOVCC(1.8V)	Interface power supply: 1.8V
15	GND	Ground
16	RESET	Reset pin
17	GND	Ground
18	TE	Tearing effect output pin to synchronize MCU to frame writing, activated by S/W command.
19	GND	Ground
20	MIPI_D3P	Differential data pairs for MIPI interface(+).
21	NC	NC
22	MIPI_D3N	Differential data pairs for MIPI interface(-).
23	GND	Ground
24	MIPI_D2P	Differential data pairs for MIPI interface(+).
25	NC	NC
26	MIPI_D2N	Differential data pairs for MIPI interface(-).
27	GND	Ground
28	MIPI_CLKP	Differential clock or strobe pair for MIPI interfaces(+).
29	NC	NC
30	MIPI_CLKN	Differential clock or strobe pair for MIPI interfaces(-).
31	GND	Ground
32	MIPI_D1P	Differential data pairs for MIPI interface(+).
33	NC	NC
34	MIPI_D1N	Differential data pairs for MIPI interface(-).
35	GND	Ground
36	MIPI_D0P	Differential data pairs for MIPI interface(+).
37	NC	NC
38	MIPI_D0N	Differential data pairs for MIPI interface(-).
39-40	GND	Ground

7. Timing Characteristics

7.1 Serial Interface Characteristics

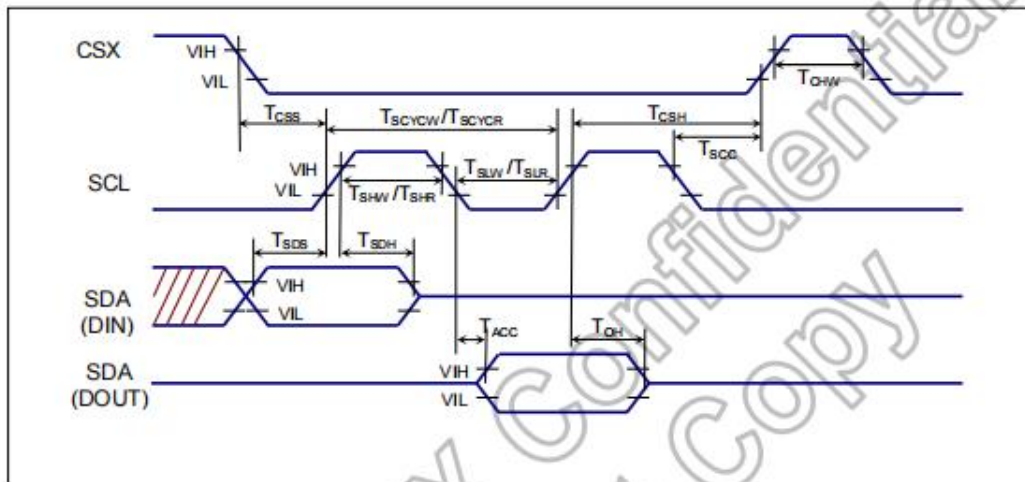

Figure 7.3: Serial Interface Characteristics

(VSSA=0V, IOVCC=1.8V, VCI=2.8V, TA = 25°C)

Signal	Symbol	Parameter	Min.	Max.	Unit	Description
CSX	t_{CSS}	Chip select setup time (Write)	15	-	ns	-
	t_{CSS}	Chip select setup time (Read)	60	-		
	t_{CSH}	Chip select hold time (Write)	15	-		
	t_{CSH}	Chip select hold time (Read)	65	-		
DCX	t_{AST}	Address setup time	0	-	ns	-
	t_{AHT}	Address hold time (Write/Read)	10	-		
SCL (Write)	t_{WC}	Write cycle	66	-	ns	-
	t_{WRH}	Control pulse "H" duration	15	-		
	t_{WRL}	Control pulse "L" duration	15	-		
SCL (Read)	t_{RC}	Read cycle	150	-	ns	-
	t_{RDH}	Control pulse "H" duration	60	-		
	t_{RDL}	Control pulse "L" duration	60	-		
SDA (Input)	t_{DS}	Data setup time	10	-	ns	For maximum $C_L=30pF$ For minimum $C_L=8pF$
	t_{DH}	Data hold time	10	-		
SDA (Output)	t_{ACC}	Read access time	-	100	ns	
	t_{OH}	Output disable time	10	-		

Note: The input signal rise time and fall time (t_r , t_f) is specified at 15 ns or less.

Logic high and low levels are specified as 30% and 70% of IOVCC for Input signals.

Table 7.2: Serial Interface Characteristics

7.2 DSI Interface Timing Characteristics

High Speed Mode

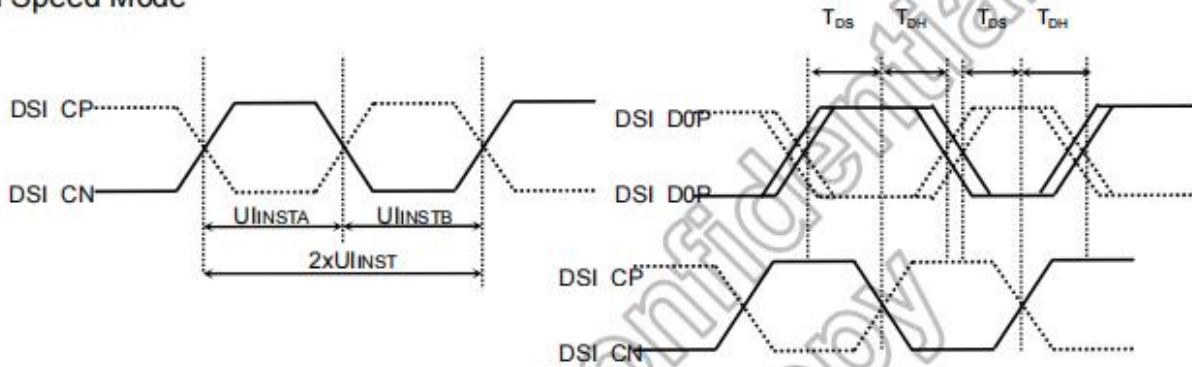

Figure 7.4: DSI clock timing Characteristics

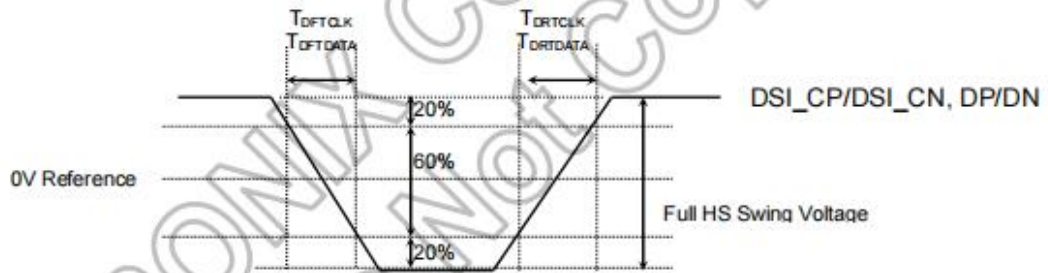

Figure 7.5: Rising and falling time on clock and data channel

(VSSA=0V, IOVCC=1.65V to 3.3V, VCI=2.5V to 3.3V, TA = -30 to 70°C)

Signal	Item	Symbol	Spec.			Unit
			Min.	Typ.	Max.	
DSI_CP/ DSI_CN	Double UI instantaneous	2xUIINST	TBD	-	25	ns
	UI instantaneous	UIINSTA UIINSTB	TBD	-	12.5	ns
DP/DN	Data to clock setup time	T _{DS}	0.15xUI	-	-	ps
	Data to clock hold time	T _{DH}	0.15xUI	-	-	ps
DSI_CP/ DSI_CN	Differential rise time for clock	T _{DRTCLK}	150	-	0.3UI	ps
	Differential fall time for clock	T _{DFTCLK}	150	-	0.3UI	ps
DP/DN	Differential rise time for data	T _{DRTDATA}	150	-	0.3UI	ps
	Differential fall time for data	T _{DFTDATA}	150	-	0.3UI	ps

Table 7.3: DSI High Speed Mode Characteristics

Low Power Mode

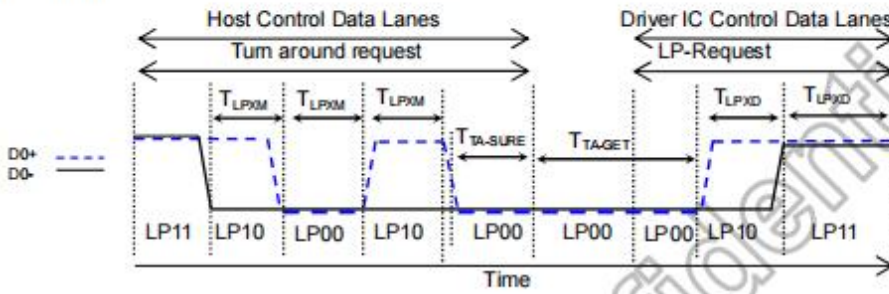

Figure 7.6: BTA from HOST to Display Module Timing

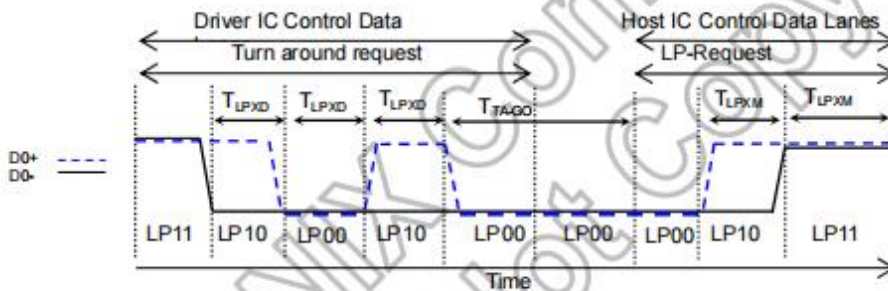

Figure 7.7: BTA from Display Module Timing to HOST

(VSSA=0V, IOVCC=1.65V to 3.3V, VCI=2.3V to 3.3V, T_A = -30 to 70°C)

Signal	Item	Symbol	Spec.			Unit
			Min.	Typ.	Max.	
DSI_D0P/ DSI_D0P	Length of LP-00/LP01/LP10/LP11 Host → Display module	T _{LPXM}	50	-	-	ns
	Length of LP-00/LP01/LP10/LP11 Display module → Host	T _{LPXD}	50	-	-	ns
	Time-out before the MPU start driver	T _{TA-SURE}	T _{LPXD}	-	2xT _{LPXD}	ns
	Time to drive LP-00 by display module	T _{TA-GET}	5xT _{LPXD}	-	-	ns
	Time to drive LP-00 after turnaround request Host	T _{TAGO}	4xT _{LPXD}	-	-	ns

Table 7.4: DSI Low Power Mode Characteristics

7.3 Reset Timing

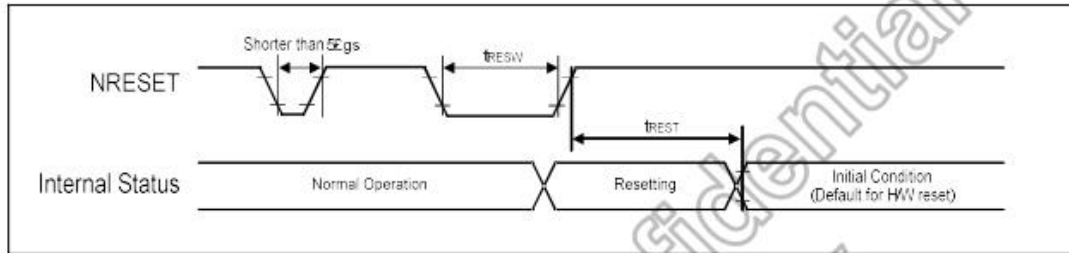

Figure 7.8: Reset input timing

Symbol	Parameter	Related Pins	Spec.			Note	Unit
			Min.	Typ.	Max.		
tRESW	Reset low pulse width ⁽¹⁾	NRESET	10	-	-	-	µs
tREST	Reset complete time ⁽²⁾	-	15	-	-	When reset applied during SLPIN mode	ms
		-	120	-	-	When reset applied during SLPOUT mode	ms

Table 7.8: Reset Input Timing

Note: (1) Spike due to an electrostatic discharge on NRESET line does not cause irregular system reset according to the following table.

NRESET Pulse	Action
Shorter than 5 µs	Reset Rejected
Longer than 10 µs	Reset
Between 5 µs and 10 µs	Reset Start

- (2) During the resetting period, the display will be blanked (The display is entering blanking sequence, which Maximum time is 120 ms, when Reset Starts in Sleep Out –mode. The display remains the blank state in Sleep In –mode) and then return to Default condition for H/W reset.
- (3) During Reset Complete Time, ID and VCOM value in OTP will be latched to internal register during this period. This loading is done every time when there is H/W reset complete time (tREST) within 15ms after a rising edge of NRESET.
- (4) Spike Rejection also applies during a valid reset pulse as shown as below:

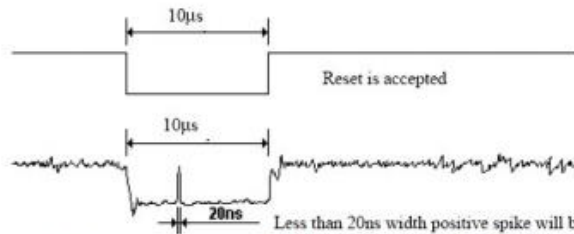

- (5) It is necessary to wait 15msec after releasing NRESET before sending commands. Also Sleep Out command cannot be sent for 120msec.

8.Outline Dimension

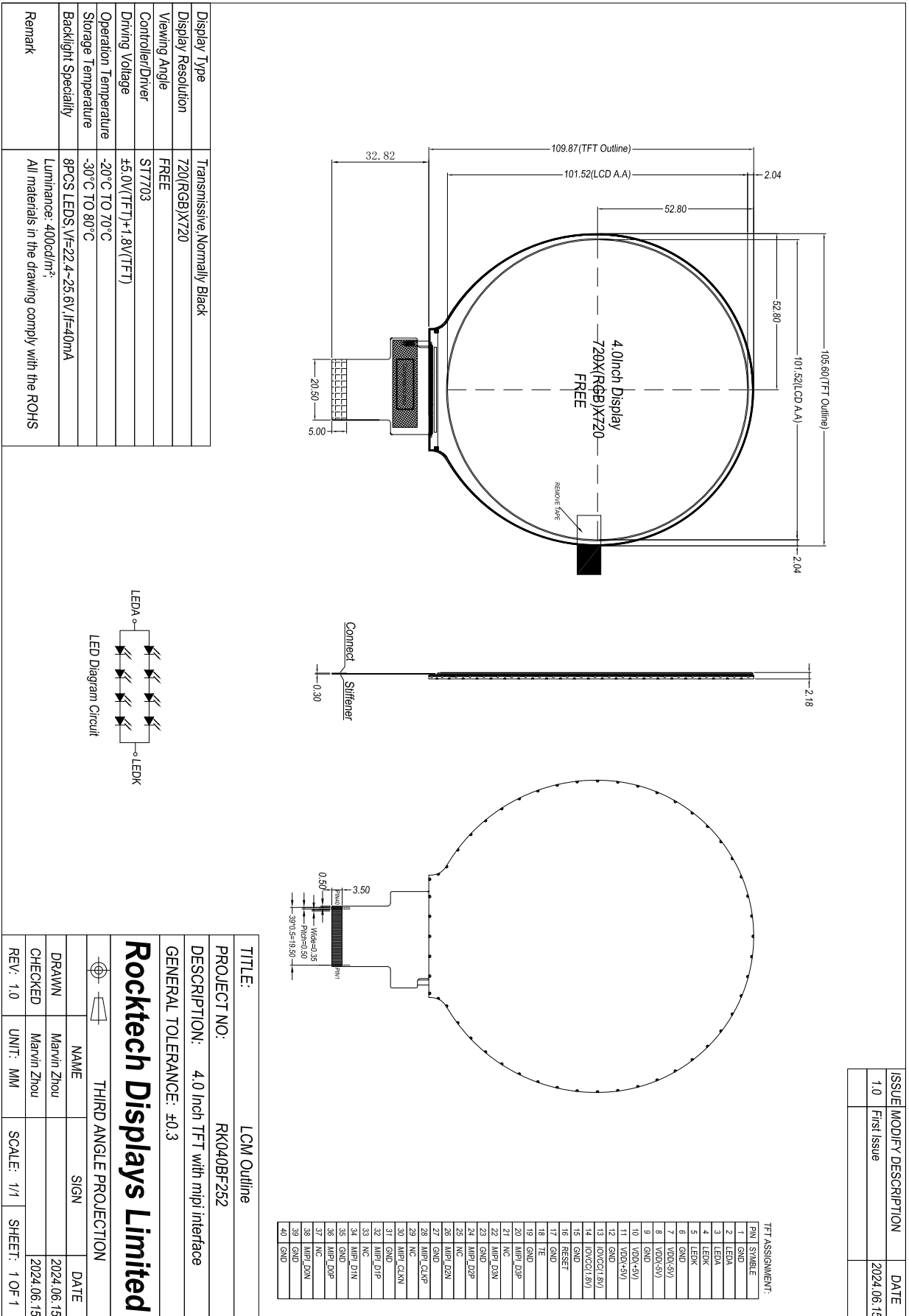

9. Reliability and Inspection Standard

No.	Test Item		Test Conditions	Remark
1	High Temperature	Storage	80°C, 120Hr	Note
		Operation	70°C, 120Hr	Note
2	Low Temperature	Storage	-30°C, 120Hr	Note
		Operation	-20°C, 120Hr	
3	High Temperature and High Humidity		40°C, 90%RH, 120Hr	Note
4	Thermal Cycling Test(No operation)		-20°C for 30min, 70°C for 30 min. 100 cycles. Then test at room temperature after 1 hour	Note
5	Vibration Test(No operation)		Frequency :10~55 HZ; Stroke :1.5 mm;Sweep:10HZ~55HZ~10HZ; 2hours for each direction of X, Y, Z(6 hours for total)	
6	Package Drop Test		Height:60 cm,1 corner, 3 edges, 6 surfaces	
7	Electro Static Discharge		±2KV,Human Body Mode, 100pF/1500Ω	

Note:

- 1) Sample quantity for each test item is 5~10pcs.
- 2) Note 4: Before cosmetic and function test, the product must have enough recovery time, at least 2 hours at room temperature.

10. PRECAUTIONS FOR USING LCD MODULES

Handling Precautions

- (1) The display panel is made of glass and polarizer. As glass is fragile, it tends to become or chipped during handling especially on the edges. Please avoid dropping or jarring. Do not subject it to a mechanical shock by dropping it or impact.
- (2) If the display panel is damaged and the liquid crystal substance leaks out, be sure not to get any in your mouth. If the substance contacts your skin or clothes, wash it off using soap and water.
- (3) Do not apply excessive force to the display surface or the adjoining areas since this may cause the color tone to vary. Do not touch the display with bare hands. This will stain the display area and degraded insulation between terminals (some cosmetics are determined to the polarizer).
- (4) The polarizer covering the display surface of the LCD module is soft and easily scratched. Handle this polarizer carefully. Do not touch, push or rub the exposed polarizers with anything harder than an HB pencil lead (glass, tweezers, etc.). Do not put or attach anything on the display area to avoid leaving marks on. Condensation on the surface and contact with terminals due to cold will damage, stain or dirty the polarizer. After products are tested at low temperature they must be warmed up in a container before coming is contacting with room temperature air.
- (5) If the display surface becomes contaminated, breathe on the surface and gently wipe it with a soft dry cloth. If it is heavily contaminated, moisten cloth with one of the following solvents
 - Isopropyl alcohol
 - Ethyl alcoholDo not scrub hard to avoid damaging the display surface.
- (6) Solvents other than those above-mentioned may damage the polarizer. Especially, do not use the following.
 - Water
 - Ketone
 - Aromatic solventsWipe off saliva or water drops immediately, contact with water over a long period of time may cause deformation or color fading. Avoid contacting oil and fats.
- (7) Exercise care to minimize corrosion of the electrode. Corrosion of the electrodes is accelerated by water droplets, moisture condensation or a current flow in a high-humidity environment.
- (8) Install the LCD Module by using the mounting holes. When mounting the LCD module make sure it is free of twisting, warping and distortion. In particular, do not forcibly pull or bend the I/O cable or the backlight cable.
- (9) Do not attempt to disassemble or process the LCD module.
- (10) NC terminal should be open. Do not connect anything.
- (11) If the logic circuit power is off, do not apply the input signals.
- (12) Since LCM has been assembled and adjusted with a high degree of precision, avoid applying excessive shocks to the module or making any alterations or modifications to it.
 - Do not alter, modify or change the shape of the tab on the metal frame.
 - Do not make extra holes on the printed circuit board, modify its shape or change the positions of components to be attached.
 - Do not damage or modify the pattern writing on the printed circuit board.
 - Absolutely do not modify the zebra rubber strip (conductive rubber) or heat seal

connector.

- Except for soldering the interface, do not make any alterations or modifications with a soldering iron.
- Do not drop, bend or twist LCM.

Storage Precautions

When storing the LCD modules, the following precaution is necessary.

- (1) Store them in a sealed polyethylene bag. If properly sealed, there is no need for the dessicant.
- (2) Store them in a dark place. Do not expose to sunlight or fluorescent light, keep the temperature between 0°C and 35°C.
- (3) The polarizer surface should not come in contact with any other objects. (We advise you to store them in the container in which they were shipped).

Others

Liquid crystals solidify under low temperature (below the storage temperature range) leading to defective orientation or the generation of air bubbles (black or white). Air bubbles may also be generated if the module is subject to a low temperature.

If the LCD modules have been operating for a long time showing the same display patterns, the display patterns may remain on the screen as ghost images and a slight contrast irregularity may also appear. A normal operating status can be regained by suspending use for some time. It should be noted that this phenomenon does not adversely affect performance reliability.

To minimize the performance degradation of the LCD modules resulting from destruction caused by static electricity etc., exercise care to avoid holding the following sections when handling the modules.

- Exposed area of the printed circuit board.
- Terminal electrode sections.